



Intermediate Proofer

02

*Intermediate Pocket Proofer with capacity
1800 or 3000 pieces/hour.
Weight range between 100-1500 grams.*

FOR WHO?

Bakeries.
Semi-Industrial Bakeries.

WHY IPP?



Silent Operation



Modular System



Easy to clean



MEASUREMENTS AND DRAWINGS [MM]

Front view

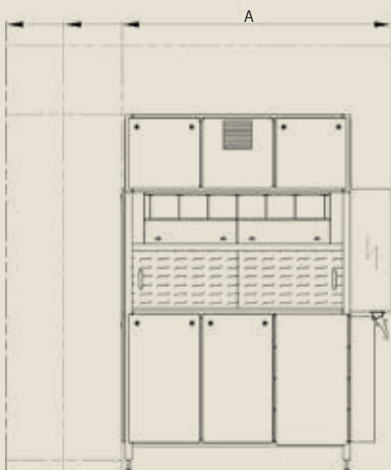

Side view.

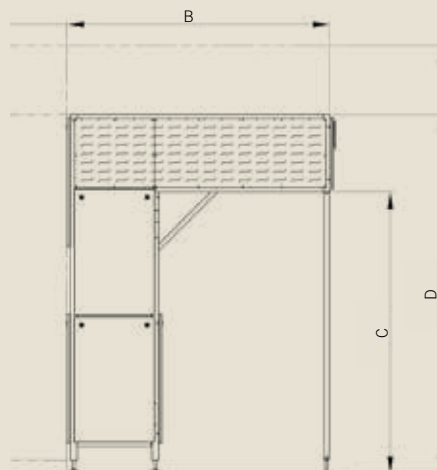

Pockets / MM	A	B	C	D
6 Pockets	1955	1930	2040	2600
8 Pockets	2375	1930	2040	2600
10 Pockets	2795	1930	2040	2600
12 Pockets	3215	1930	2040	2600
Extra module	-	+ 590	-	-
Height extension module	-	-	+ 500	+ 500

Intermediate Pocket Proofer

IPP

One of the most flexible pocket proofers on the market. For 6, 8, 10 or 12 pockets. Modulated for possible adaption in height and width, available in standard models from 132 up to 1128 effective pockets, larger proofers on request. Solid construction in stainless steel materials.

FEATURES AND BENEFITS

- Models with 6-, 8-, 10- or 12-pockets swings.
- Modular system for up to 1128 pockets net as standard.
- Stainless steel execution - easy to keep clean.
- Flexible layout - choice of infeed position.
- Weight range 100-1500 g.
- 2 different infeed systems, capacity up to 1800 or 3000 pieces/hour.
- Encapsulated design - prevents skin forming on the dough.
- Non-stick coated transfer box.
- Motor drive directly on shaft (no chains or timing belts).
- Operation panel easy accessible under projecting overhang.
- Electrical cabinet at working height with power supply and sockets for divider, rounder and moulder.
- Silent operation.
- Adjustable resting time.
- Parts in blue for better detection and food safety.

OPTIONS

- Collection drawers.
- UV-lightning.
- Synchronized speed with divider.
- Outfeed cross conveyor (standard for IPP 3000 pieces/hour).
- Outfeed cross conveyor, reversible, additional price.
- Guiding plates.
- Humidification system.
- Outlet sliding plate (unavailable with IPP 3000 pieces/hour).
- Infeed from back side.
- Common E-Stop - stop all bread line components with any emergency stop in the bread line (only with complete bread line)*
- Overfill Detection System - Photocell System that reduces the need for monitoring the bread line. The Photocell System detects any larger dough spillage in the upper cabinet overhang and automatically stops the IPP for cleaning in time before large accumulations of dough are created.

* Common E-Stop - Use the emergency stop from any component in the bread line to completely stop all the machines included in the line. As standard you must push the IPP emergency stop to stop all machines.

TECHNICAL

Capacity range	1800 or 3000 pieces/hour.
Weight range	100-1500 g.
Recommended Fuse IPP only (amp)	16 A.
	(depending on connected make-up machines 16 - 25 A)
Power supply	5.95-8.63 kW.
	(depending on connected make-up machines)
Air supply (double infeed)	6 bar.

CALCULATE NUMBER OF EFFECTIVE POCKETS

Formula for calculating number of needed effective pockets:

$$\frac{\text{Capacity rate / hour}}{60} \times \text{desired proofing time in minutes} = \text{total Effective Pockets}$$

04



Intermediate Pocket Proofer

CAPACITY AND EFFECTIVE POCKETS

MAX CAPACITY, PIECES/HOUR	1800 (1)		3000 (2)	
NO. OF POCKETS IN EACH SWING/NUMBER OF EFFECTIVE SWINGS*	EFFECTIVE POCKETS	PROOFING TIME AT 1800 PIECES/HOUR	EFFECTIVE POCKETS	PROOFING TIME AT 3000 PIECES/HOUR
LOW PROOFERS H = 2600 MM**				
6/22	132	4.3	–	–
8/22	176	5.7	176	3.4
10/22	220	7.1	220	4.3
12/22	264	8.5	264	5.1
6/40	240	7.8	–	–
8/40	320	10.3	320	6.2
10/40	400	12.9	400	7.8
12/40	480	15.5	480	9.3
6/60	360	11.6	–	–
8/60	480	15.5	480	9.3
10/60	600	19.4	600	11.6
12/60	720	23.3	720	14.0
6/78	468	15.1	–	–
8/78	624	20.2	624	12.1
10/78	780	25.2	780	15.1
12/78	936	30.3	936	18.2
HIGH PROOFERS H = 3100 MM				
6/26	156	5.0	–	–
8/26	208	6.7	208	4.0
10/26	260	8.4	260	5.0
12/26	312	10.1	312	6.1
6/48	288	9.3	–	–
8/48	384	12.4	384	7.4
10/48	480	15.5	480	9.3
12/48	576	18.6	576	11.2
6/72	432	14.0	–	–
8/72	576	18.6	576	11.2
10/72	720	23.3	720	14.0
12/72	864	27.9	864	16.8
6/94	564	18.2	–	–
8/94	752	24.3	752	14.6
10/94	940	30.4	940	18.2
12/94	1128	36.5	1128	21.9

*Total number of swings is always 4 more than effective number of swings.

**Not recommended in combination with the MO881 Moulder.

(1) IPP with single infeed V-belt conveyor L=750mm. Photocell controlled, non-stick coated, infeed conveyor combined with continuous pocket proofer drive. Variable speed on the proofer. Control panel under a projecting overhang, power supplies for the divider, rounder and moulder.

(2) IPP with dual infeed conveyor L=750 mm, centrally placed, photocell controlled, non-stick coated infeed V-belt conveyors. Flap system guides the dough pieces after the rounder. Compressed air is required, 6 bar. Variable speed on the proofer. Control panel under a projecting overhang, power supplies for the divider, rounder and moulder, and the outfeed cross conveyor.

06

Intermediate Conveyor Proofer with capacity up to 3600 pieces/hour. Weight range up to 2000 grams.

FOR WHO?

Bakeries.
Semi-Industrial Bakeries.
Industrial Bakeries.

WHY ICP?



Easy to clean



Flexible Design



MEASUREMENTS AND DRAWINGS [MM]

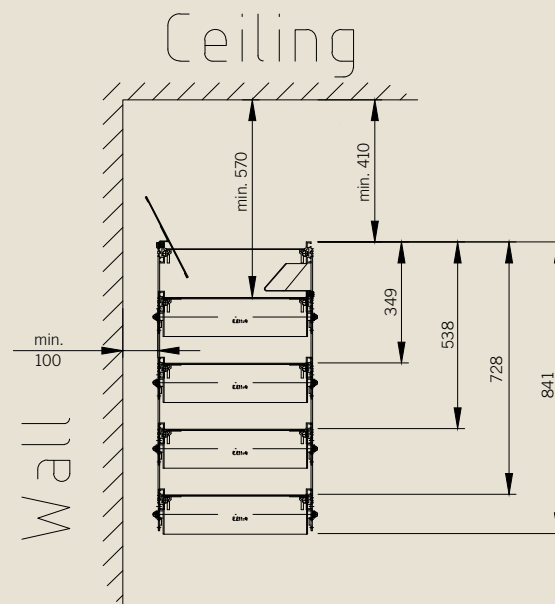

Intermediate Conveyor Proofer

ICP

A conveyor proofer for all types of bakeries. Can be made in 1-4 decks as standard and customized lengths. Space saving system, can be mounted from ceiling.

FEATURES AND BENEFITS

- Capacity up to 3600 pcs/hour.
- Weight range up to 2000 g.
- Belt width 350 mm.
- Made of strong special aluminum profiles.
- Drum motors with frequency controlled drive as standard.
- Standard length up to 12 m on each deck.
- Outlet sliding plate - fixed (option).
- Outlet sliding plate - turnable 1500 mm or 2500 mm (option).
- Removable windows on both sides.
- Separate stands (option).
- Ceiling suspensions (option).
- Flexible layout regarding length and decks.
- Adjustable resting time.
- Saves floor space.
- Technical drawing required.

OPTIONS

- Set of ceiling suspensions – one for drive end and one for each 2,5 m.
- Separate stands (legs) – one for drive end and one for each 2,5 m.
- Wall supports - depending on structural stability.
- Outlet sliding plate - Turnable L =1500 mm.
- Outlet sliding plate - Turnable L =2500 mm.
- Outlet sliding plate - Fixed.
- Straight in-line feeding.

MODELS

- ICP100 - 1 deck x 5 m.
- ICP200 - 2 decks x 5 m.
- ICP300 - 3 decks x 5 m.
- ICP400 - 4 decks x 5 m.
- ICP without control cabinet.
- ICP with control cabinet.
- Additional price per meter (proofing length).

TECHNICAL

Capacity range	up to 3600 pieces/hour.
Weight range	100-2000 g.
	(subject to capacity and dough characteristics)
Recommended fuse (amp)	16 A.
Power supply	0.11 kW/deck as standard.

CALCULATE CONVEYOR PROOFING LENGTH

Formula for calculating conveyor proofing length (in meters):

$$\frac{\text{Capacity rate/hour}}{60} \times \text{desired proofing time in minutes} \times A$$

- A = 0.25 (meters) for dough pieces over 1 kg.
- A = 0.20 (meters) for dough pieces up to 1 kg.

Our story

We provide customized baking solutions, dough handling equipment systems and complete bread lines for professional baking businesses.

We offer reliable technology with precision control and flexibility regarding weights and types of dough and also user-friendly design that gives baking professionals creative freedom at the lowest cost of ownership.

Sveba Dahlen AB
Industrivägen 8
513 82 Fristad, Sweden

www.sveba.com
info@glimek.com

